

REVISIONS					
P	LTR	DESCRIPTION	DATE	DWN	APVD
W		REVISED PER ECO-20-001327	05JUN2020	SB	JO

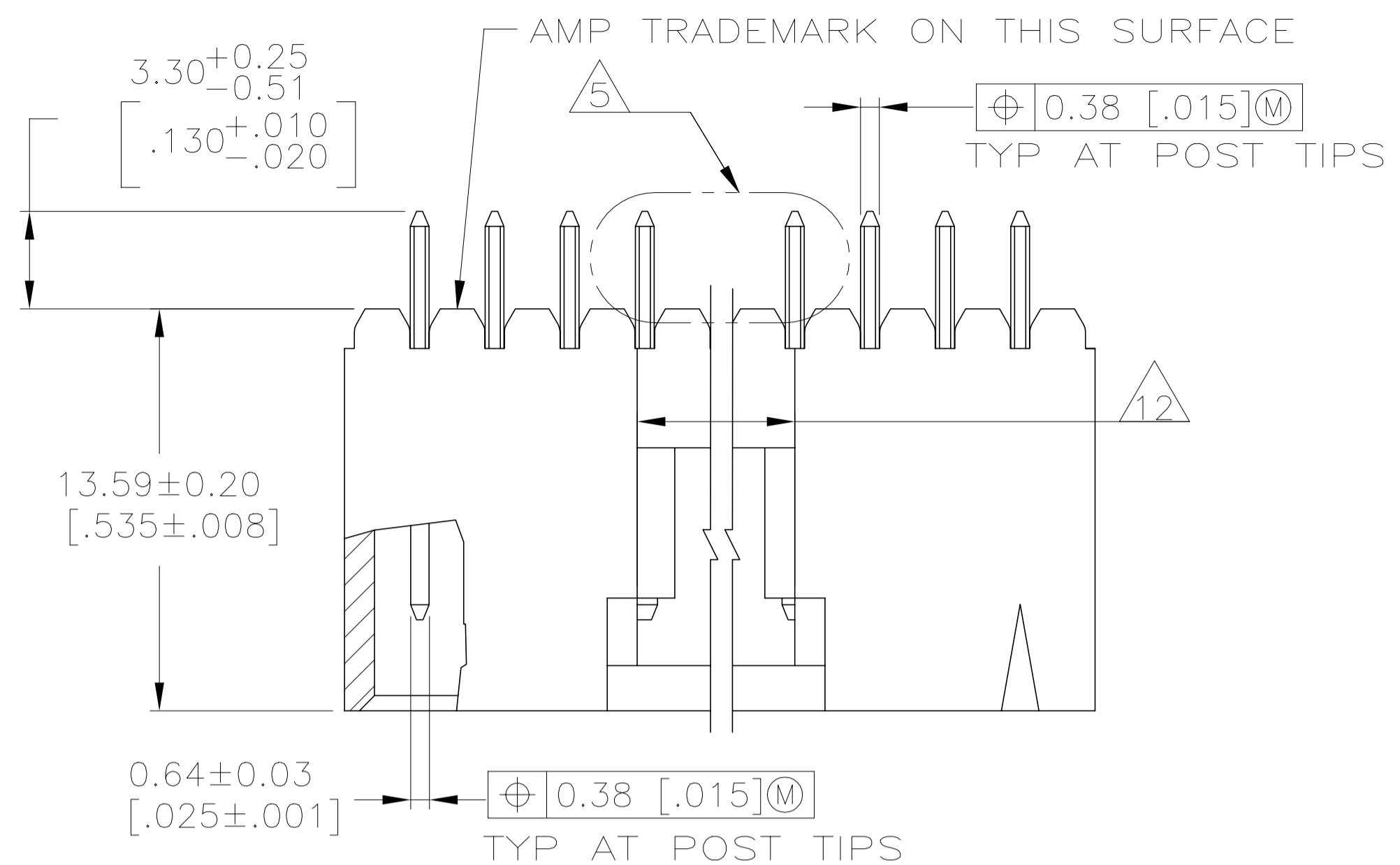

- 1 0.000381 [.000015] GOLD IN THE CONTACT AREA, 0.00254-0.00508 [.000100-.000200] MATTE TIN-LEAD ON THE SOLDER TAIL, ALL OVER ALL OVER 0.00127 [.000050] NICKEL.
- 2 POINT OF MEASUREMENT FOR PLATING THICKNESS
- 3 THE NOTED DIMENSIONS APPLY FROM THE BASIC DIMENSION LINE (NOT THE POST CENTERLINE) TO THE SURFACE INDICATED
- 4 ONE POLARIZATION SLOT FOR 2 AND 3 POSITION ASSEMBLIES ONLY.
- 5 SELECT POST TAILS FORMED TO PROVIDE CONNECTOR HOLD DOWN UNTIL SOLDERED, CONFIGURATION ACCEPTS 0.69-2.03 [.027-.080] THICK PRINTED CIRCUIT BOARD (SEE DETAIL Z).
- 6 DIMENSIONS NOTED ARE FOR SOLDER STENCIL LAYOUT FOR USE WITH 1.57±0.20 [.062±.008] THICK PRINTED CIRCUIT BOARDS.
- 7 PARTS ARE PACKAGED IN GANG OF TUBES

- 8 OBSOLETE PART NO., REFER TO DWG 104909 FOR POS 13 THRU 25.
- 9 HOUSING: HIGH TEMPERATURE LCP, COLOR-BLACK. POSTS: BRASS.
- 10 0.000381 [.000015] GOLD IN THE CONTACT AREA, 0.00254-0.00508 [.000100-.000200] MATTE TIN ON THE SOLDER TAIL, ALL OVER ALL OVER 0.00127 [.000050] NICKEL.
- 11 SUPERSEDED
- 12 0.25 [.010] RECESS PERMISSIBLE IN THIS AREA FOR MOLD SHUT OFF

PART NO.	SUPERSEDED BY
1-104362-2	1-104909-2
1-104362-4	1-104909-4
1-104362-7	1-104909-7
2-104362-2	—
2-104362-3	—

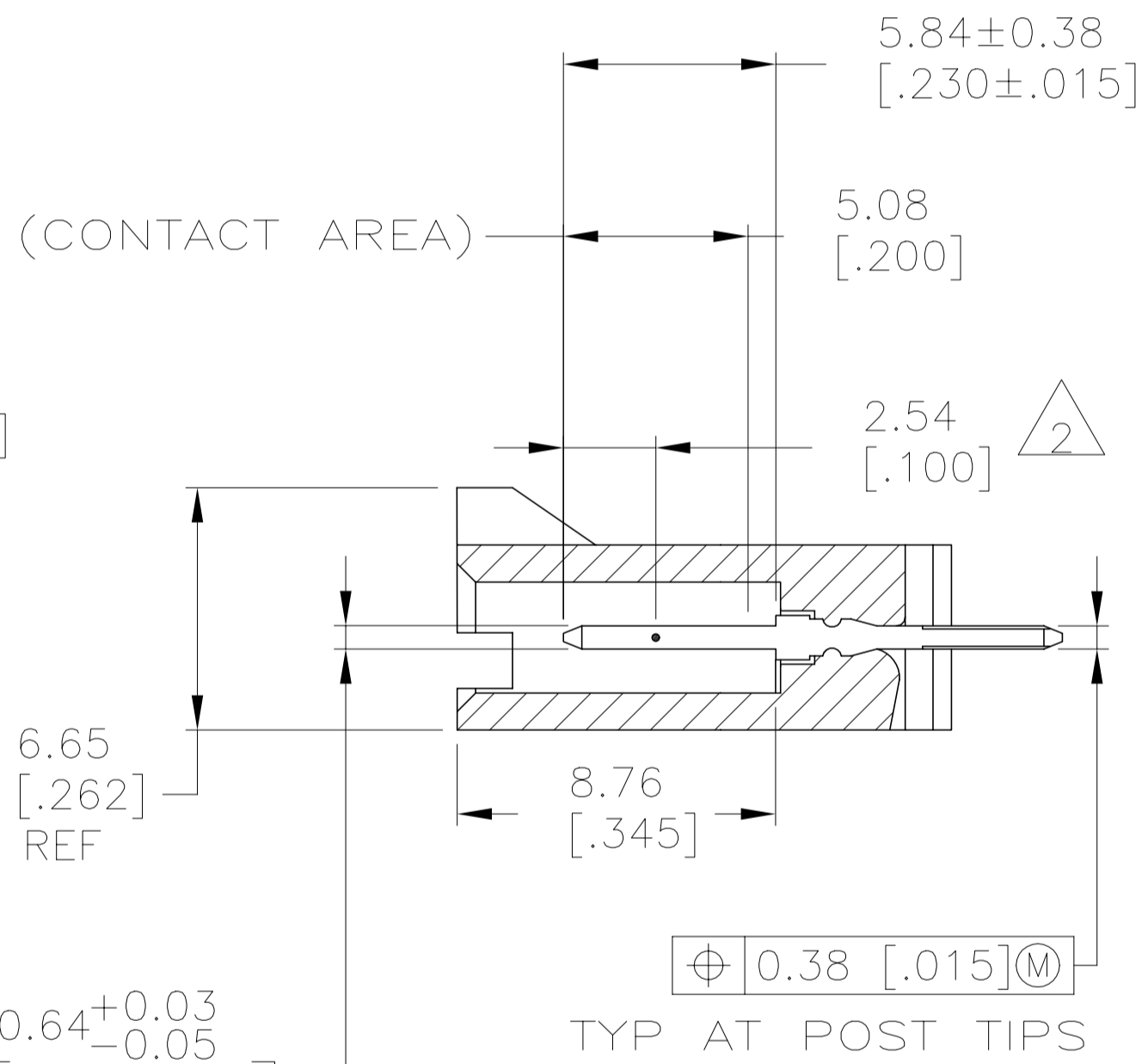
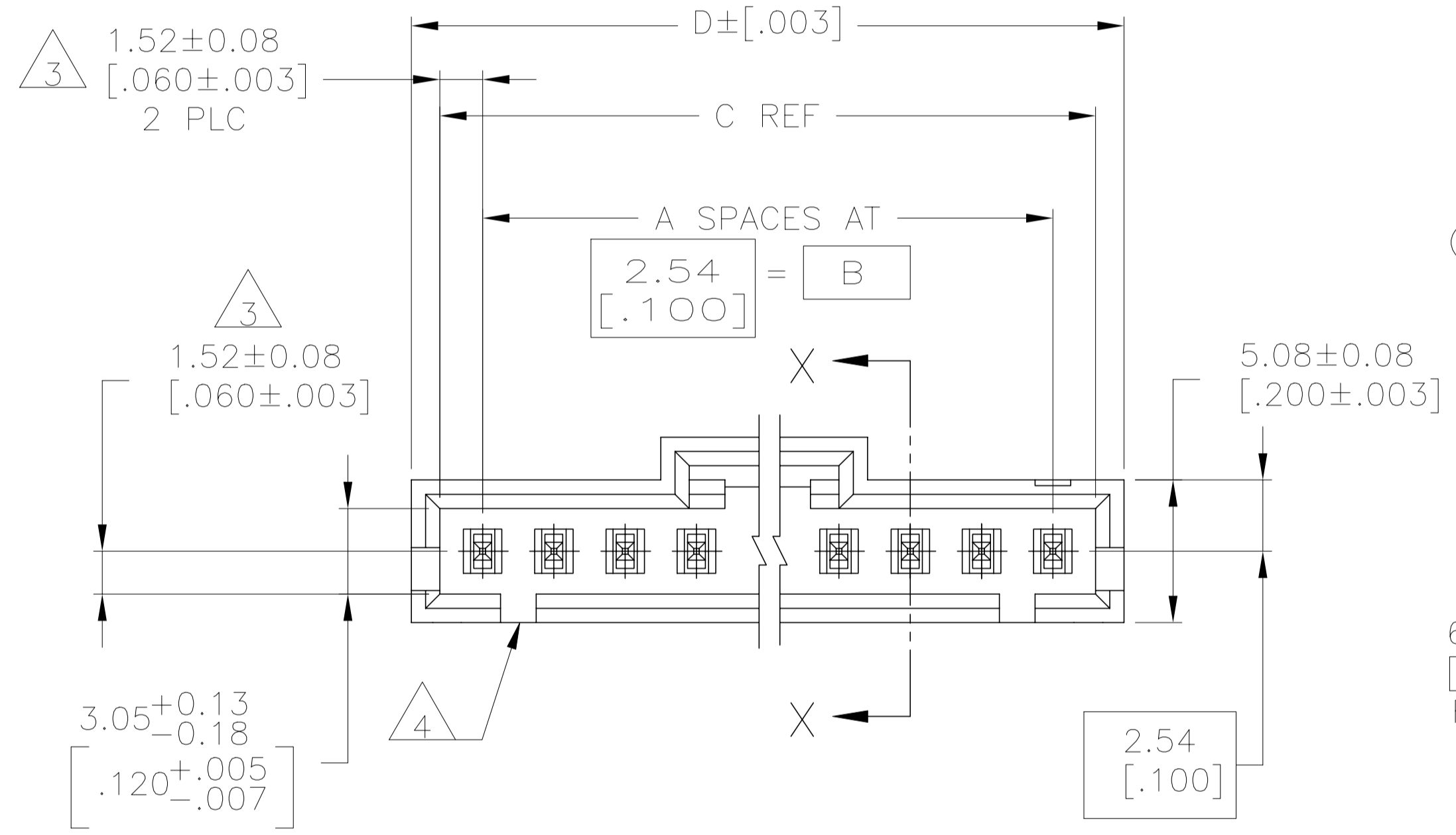

PLATING	D	C	B	A	NO OF POSN	ASSEMBLY PART NUMBER
10	32.89 [1.295]	30.99 [1.220]	27.94 [1.100]	11	12	6-104362-1
10	30.35 [1.195]	28.45 [1.120]	25.4 [1.000]	10	11	6-104362-0
10	27.81 [1.095]	25.91 [1.020]	22.86 [.900]	9	10	5-104362-9
10	25.27 [0.995]	23.37 [.920]	20.32 [.800]	8	9	5-104362-8
10	22.73 [.895]	20.83 [.820]	17.78 [.700]	7	8	5-104362-7
10	20.19 [.795]	18.29 [.720]	15.24 [.600]	6	7	5-104362-6
10	17.65 [.695]	15.75 [.620]	12.7 [.500]	5	6	5-104362-5
10	15.11 [.595]	13.21 [.520]	10.16 [.400]	4	5	5-104362-4
10	12.57 [.495]	10.67 [.420]	7.62 [.300]	3	4	5-104362-3
10	10.03 [.395]	8.13 [.320]	5.08 [.200]	2	3	5-104362-2
10	7.49 [.295]	5.59 [.220]	2.54 [.100]	1	2	5-104362-1
10	65.91 [2.595]	64.01 [2.520]	60.96 [2.400]	24	25	2-104362-4
10	63.37 [2.495]	61.47 [2.420]	58.42 [2.300]	23	24	2-104362-3
10	60.83 [2.395]	58.93 [2.320]	55.88 [2.200]	22	23	2-104362-2
10	58.29 [2.295]	56.39 [2.220]	53.34 [2.100]	21	22	2-104362-1
10	55.75 [2.195]	53.85 [2.120]	50.8 [2.000]	20	21	2-104362-0
10	53.21 [2.095]	51.31 [2.020]	48.26 [1.900]	19	20	1-104362-9
10	50.67 [1.995]	48.77 [1.920]	45.72 [1.800]	18	19	1-104362-8
10	48.13 [1.895]	46.23 [1.820]	43.18 [1.700]	17	18	1-104362-7
10	45.59 [1.795]	43.69 [1.720]	40.64 [1.600]	16	17	1-104362-6
10	43.05 [1.695]	41.15 [1.620]	38.1 [1.500]	15	16	1-104362-5
10	40.51 [1.595]	38.61 [1.520]	35.56 [1.400]	14	15	1-104362-4
10	37.97 [1.495]	36.07 [1.420]	33.02 [1.300]	13	14	1-104362-3
10	35.43 [1.395]	33.53 [1.320]	30.48 [1.200]	12	13	1-104362-2
10	32.89 [1.295]	30.99 [1.220]	27.94 [1.100]	11	12	1-104362-1
10	30.35 [1.195]	28.45 [1.120]	25.4 [1.000]	10	11	1-104362-0
10	27.81 [1.095]	25.91 [1.020]	22.86 [.900]	9	10	104362-9
10	25.27 [0.995]	23.37 [.920]	20.32 [.800]	8	9	104362-8
10	22.73 [.895]	20.83 [.820]	17.78 [.700]	7	8	104362-7
10	20.19 [.795]	18.29 [.720]	15.24 [.600]	6	7	104362-6
10	17.65 [.695]	15.75 [.620]	12.7 [.500]	5	6	104362-5
10	15.11 [.595]	13.21 [.520]	10.16 [.400]	4	5	104362-4
10	12.57 [.495]	10.67 [.420]	7.62 [.300]	3	4	104362-3
10	10.03 [.395]	8.13 [.320]	5.08 [.200]	2	3	104362-2
10	7.49 [.295]	5.59 [.220]	2.54 [.100]	1	2	104362-1

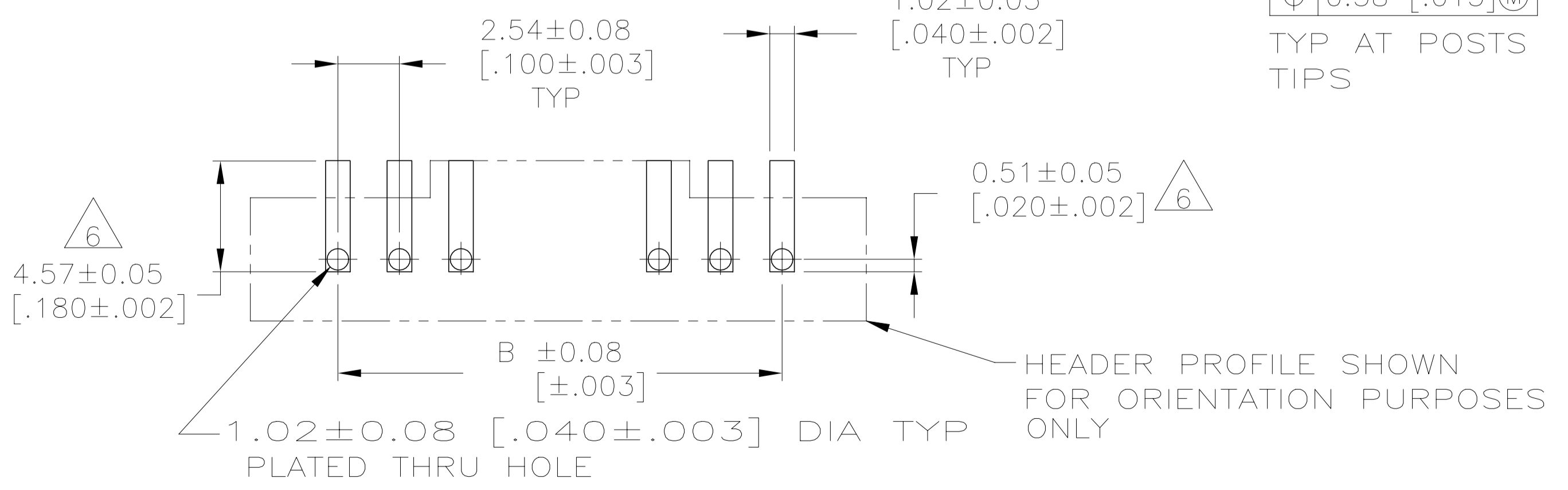

RECOMMENDED PC BOARD MOUNTING DIMENSIONS
 RECOMMENDED STENCIL THICKNESS = 0.25 [.010]

THIS DRAWING IS A CONTROLLED DOCUMENT. DWN G DOUTY 2-22-88
 CHK T C CLARK 2-22-88

DIMENSIONS: mm [INCHES] TOLERANCES UNLESS OTHERWISE SPECIFIED:
 0 PLC ± -
 1 PLC ± -
 2 PLC ± -
 3 PLC ± .005
 4 PLC ± -
 ANGLES ± -

PRODUCT SPEC
 APPLICATION SPEC

MATERIAL FINISH SEE TABLE

WEIGHT -

CUSTOMER DRAWING

NAME
 HEADER ASSY, AMPMODU MTE, VERTICAL SINGLE ROW, .100 C/L, .025 SQ POST POLARIZED, WITH LATCHING & HOLD DOWN

SIZE A2 CAGE CODE 00779 DRAWING NO C=104362 RESTRICTED TO -

SCALE 4:1 SHEET 1 OF 1 REV W